

3D model is available on request

Specifications

Max. working pressure	250 bar
Weight	329 kg
Working volume	98 L
Total volume	106 L
Max. cyl. load (start tipping)	245 kN
Max. cyl. load (end of stroke) ²	121 kN
Max. cyl. load (end of stroke) ³	141 kN

Max. pump flow

With KO ¹	190 L/min
Without KO ¹	137 L/min
With KO ¹ below -20°C	133 L/min
Without KO ¹ below -20°C	96 L/min

Tipping time

With KO ¹	31 sec
Without KO ¹	43 sec
With KO ¹ below -20°C	44 sec
Without KO ¹ below -20°C	61 sec
Allowable lowering time	31 sec

Extension	1	2	3	4	5	6	7	Total
Effective diameter [mm]	169	149	129	110	91			
Stroke* [mm]	1410	1430	1430	1430	1430			7130

Technical notes

- This cylinder is a lifting device only. • It should not be used as a structural member and should not be subjected to side loads. • Tipping valve must have a pressure relief at the cylinder port set not higher than max. working pressure. • Verify max. cyl. load. • Working temperature range is between -40°C and +80°C. • Max. duration of extension is 0.5 hours (excluded hard chromed stages). • Cylinder is painted black (RAL9005) with a min. thickness conforming to the 480 hours neutral salt spray test as per ISO 9227. • ¹ Hyva knock-off. • ² Unsubstantial unloading (sticky load). • ³ Substantial unloading.

Related documentation

Bracket options: 015BRA10 & 015BRA12

Mounting instructions: CYL-0030

Oil specifications: OIL-0011
Spec sheet explanation: CYL-0041

Tipping weight

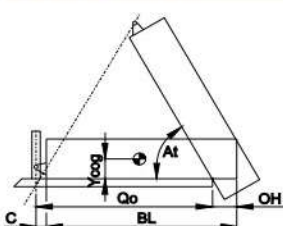

BL	body length
OH	rear overhang
Ycog	vert. pos. centre of gravity
Qo	pivot length
C	bracket length
At	tipping angle
	stroke x 60 / Qo

	9500			9150			8800		
BL [mm]	200	500	800	200	500	800	200	500	800
OH [mm]	44	46	47	46	48	49	48	50	52
At [°]									
Ycog [mm]									
600	44	47	50	45	48	52	47	50	54
900	47	50	54	48	52	56	50	54	
1200	49	53		51					

Tipping weight [ton] at maximum pressure of 250 bar for a vertically mounted cylinder and C is 229 mm

Този продукт се предлага от:



Гр. София, ул. Чelopeшко шосе 10-12
0886 441 442 / 0898 447 449
www.hydraulicstore.eu

HYDRAULIC PARTS & EQUIPMENT

Pos.	Part no.	Description	Qty.
C01	71839030	DUST COVER FC LOW 15-241	1
C02	71709632	COVER 241-1445 PIN60 A340 FIX	1
C03	01702956 K	WASHER M48 DIN 125B ZP	1
C04	01702907 K	TOPNUT NYLOC M48x3 DIN 985 ZP	1
P01	74402651	PISTON FL2 S 091-1645-HC	1
P02	71853091 K	SLIDER FL 091 (2 X 1/2) A22	1
P03	71851091 K	OUTER STOPRING FL 091 A22	1
P04	71822091	BOTTOM PLATE PISTON FL 091	1
P05	01745012 K	CIRCLIP 82 DIN 472 (87.5x2.5)	1
P06	71870215 K	O-RING PISTON BOTTOM 091	1
P07	71848200	PISTON HEAD FL 091 MK2	1
P08	01226430 K	O-RING 72.62 X 3.53 MM	1

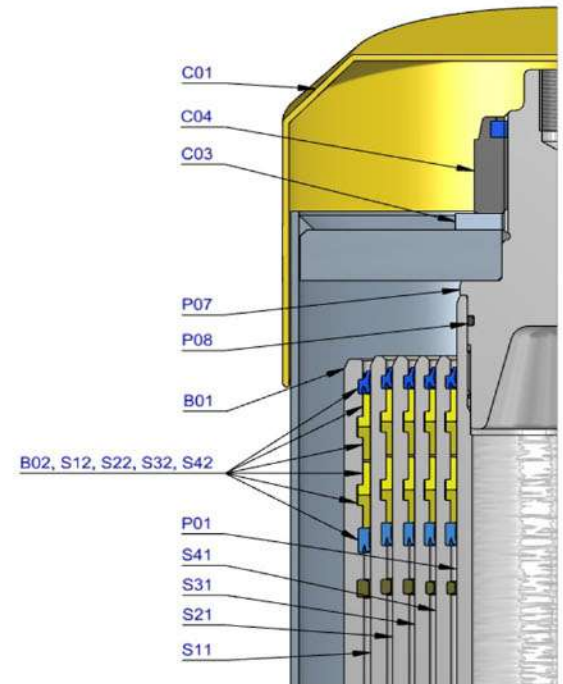

Този продукт се предлага от:



HYDRAULIC PARTS & EQUIPMENT

Гр. София, ул. Чelopeшко шосе 10-12
 0886 441 442 / 0898 447 449
www.hydraulicstore.eu

S41	74603650	STAGE FL2 110-1640	1
S42	71802110 K	PACKSET FL 110	1
S43	71853110 K	SLIDER FL 110 (2 X 1/2) A22	1
S44	71851110 K	OUTER STOPRING FL 110 A22	1
S45	71852110 K	LIFTRING FL 110 A22	1

S31	74604650	STAGE FL2 129-1640	1
S32	71802129 K	PACKSET FL 129/HP 129	1
S33	71853129 K	SLIDER FL 129 (2 X 1/2) A22	1
S34	71851129 K	OUTER STOPRING FL 129 A22	1
S35	71852129 K	LIFTRING FL 129 A22	1

S21	74605650	STAGE FL2 149-1640	1
S22	71802149 K	PACKSET FL 149/HP 150	1
S23	71807151 K	SLIDER FL 149 A35	1
S24	71851149 K	OUTER STOPRING FL 149 A22	1
S25	71852149 K	LIFTRING FL 149 A22	1

S11	74606650	STAGE FL2 169-1640	1
S12	71802169 K	PACKSET FL 169	1
S13	71807171 K	SLIDER FL 169 A35	1
S14	71851169 K	OUTER STOPRING FL 169 A22	1
S15	71813169 K	LIFTRING FL 169x5	1

B01	74507650R1345	BASE FL2 191-1683-4/4BSAE-190-C242	1
B02	71802191 K	PACKSET FL 191	1
B03	71825430	BOTTOM PLATE FL2 191	1
B04	71870040 K	SEAL BOTTOM PLATE FL 191	1
B05	71820195	LOCKING PLATE FL2 191	3
B06	01732055 K	BOLT HEX M8X20X1.25 SET 6 PCS	1
B07	01732559 K	WASHER SPRING M8 SET 6 PCS	1

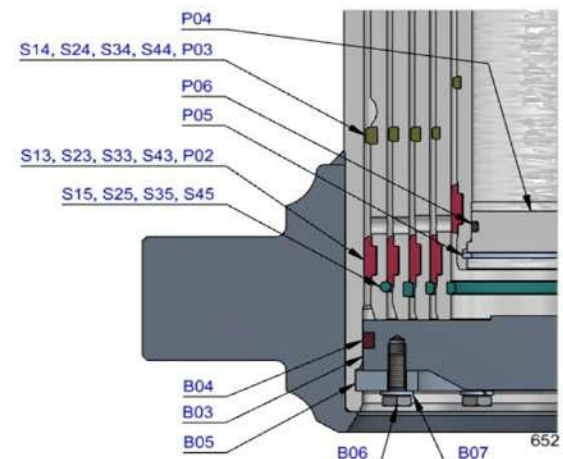
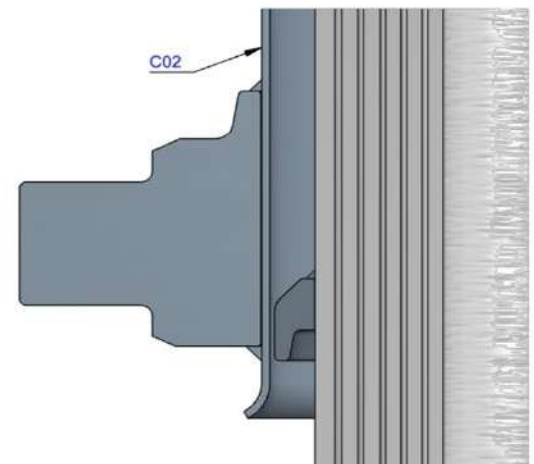

Seal kit complete

	71908650 K	Consists of all packsets with packset grease and O-rings	
--	------------	--	--

Notes

The inner stopring is pre-mounted in the grooves on spare bases and stages. Therefore, when ordering new tubes, it is not required to order inner stoprings separately.