

HYVA QUILL SHAFT



QUILL SHAFT

Hyva

Partno.:

021314009

Gearbox:

ZF

Page 1 / 1

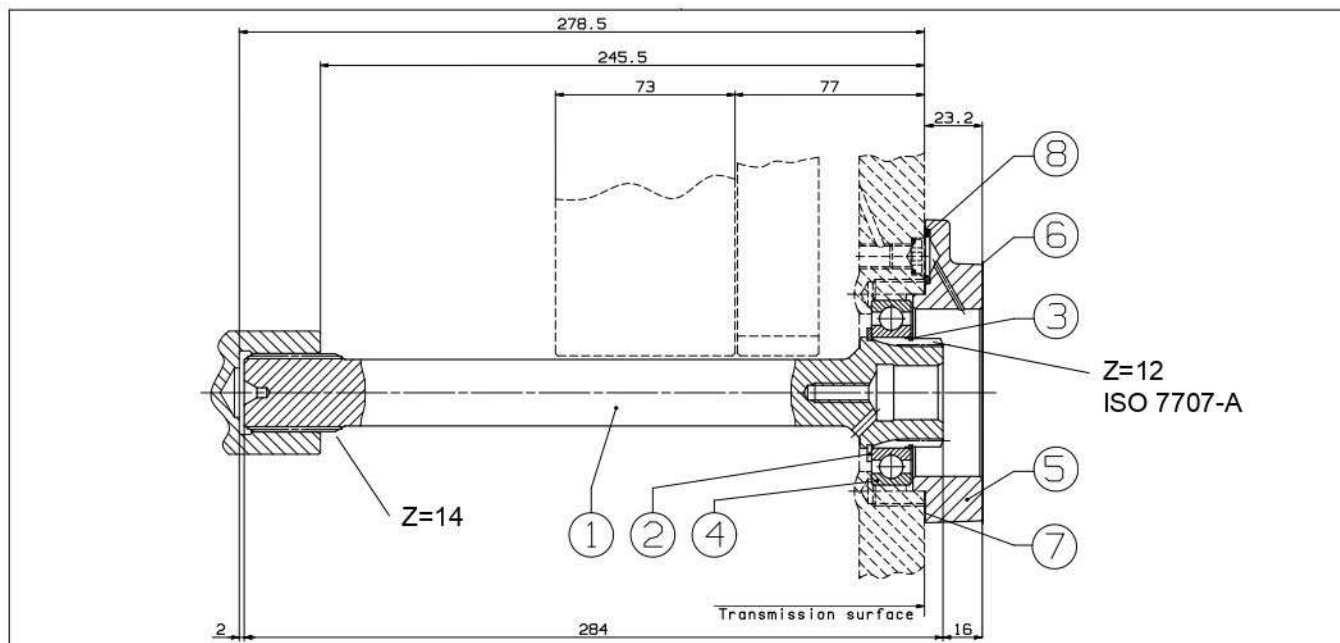

Parts list

No.	Partno.:	Description	Qty.
1		Quill shaft	1
2		Circlip E 45	1
3		Bearing back-up ring	1
4		Ball bearing 45x75x16	1
5		Bearing-holding flange	1
6		Gasket	1
7		Gasket between flange and gearbox	1
8		O-ring 3068	1

Type of Gearbox

ZF	12AS 2541TD...+INTARDER
----	-------------------------



General informations

N.B. The TCE M 10x1 plug can be removed from the transmission to guarantee adequate lubrication for the PTOs that are working in demanding conditions (high power and turns and/or prolonged working times). In the shaft kit assembly phase, confirm the correct position of the O-R pos.8 and gasket pos.7.

Този продукт се предлага от:



HYDRAULIC PARTS & EQUIPMENT

Гр. София, ул. Челопешко шосе 10-12

0886 441 442 / 0898 447 449

www.hydraulicstore.eu