

For mounting on
 • Hyva tank mounting plate

3D model is available on request

- 1 Pump connection (P)
- 2A Return tank connection (T)
- 2B Alternative return tank connection (T)
- 3 Cylinder connection (C)
- 4 Pneumatic connection (Tip)
- 5 Pneumatic connection (Lower)
- 6 Pressure gauge point
- 7 High pressure cartridge
- 8 Adjustment screw (To adjust the lowering speed)

Types

Hydraulic connections	Pressure (BAR)	Part Number	Description
	Max.		
T, C & P=1"	110	14767111	TIP VALVE HT-TNK-1220-110-P1"
	135	14767113	TIP VALVE HT-TNK-1220-135-P1"
	150	14767115	TIP VALVE HT-TNK-1220-150-P1"
	170	14767117	TIP VALVE HT-TNK-1220-170-P1"
	190	14767119	TIP VALVE HT-TNK-1220-190-P1"
	220	14767122	TIP VALVE HT-TNK-1220-220-P1"
	250	14767125	TIP VALVE HT-TNK-1220-250-P1"
	280	14767128	TIP VALVE HT-TNK-1220-280-P1"
	350	14767135	TIP VALVE HT-TNK-1220-350-P1"

Optional adapter kits	Kit number
1" Straight TNK	AK5016TS
1" 90 degree TNK	AK5016TE
1" Straight CHASSIS	AK5016CS
1" 90 degree CHASSIS	AK5016CE

Mounting kits	Kit number
Tank (TNK) *	14735168
Chassis	14735208

* = included with valve

Specifications

Type	Spool valve with pressureless bypass in neutral. Oil flow in lowering position is proportional with pneumatic pilot pressure.	
Max. peak pressure	350 bar	
Pneumatic pilot pressure	6-12 bar	
Max. pump flow	220 L/min	
Max. pressure on T-connection	10 bar	
Filtration (ISO 18/13)	25 µm	
Viscosity range	min	12 mm ² /s (cst)
	max	100 mm ² /s (cst)
Temperature range	min	-40 °C
	max	80 °C
Mass	6,1 kg	

Δp - Q characteristic

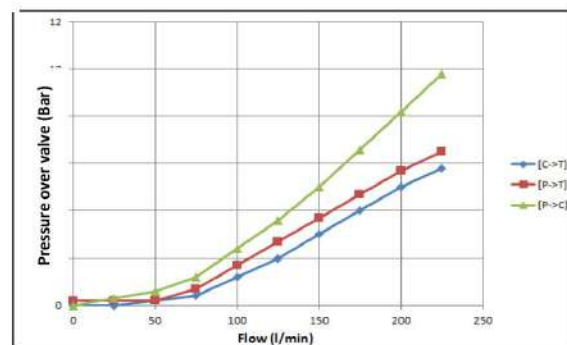

Technical notes

- Mount the valve according the mounting instructions • Use the correct washers and adapters in the ports to prevent housing deformation. Do not use adapters with tapered threads • To further prevent deformation of the valve housing, the mounting plate surface or block must be completely flat and plane.
- Do not weld to the valve. • Ideal air pressure for valve is 8 bar. • Make sure inlet air is dry.
- Paint spec: TNO00_00001

Този продукт се предлага от:



Гр. София, ул. Челопешко шосе 10-12
 0886 441 442 / 0898 447 449
www.hydraulicstore.eu

HYDRAULIC PARTS & EQUIPMENT

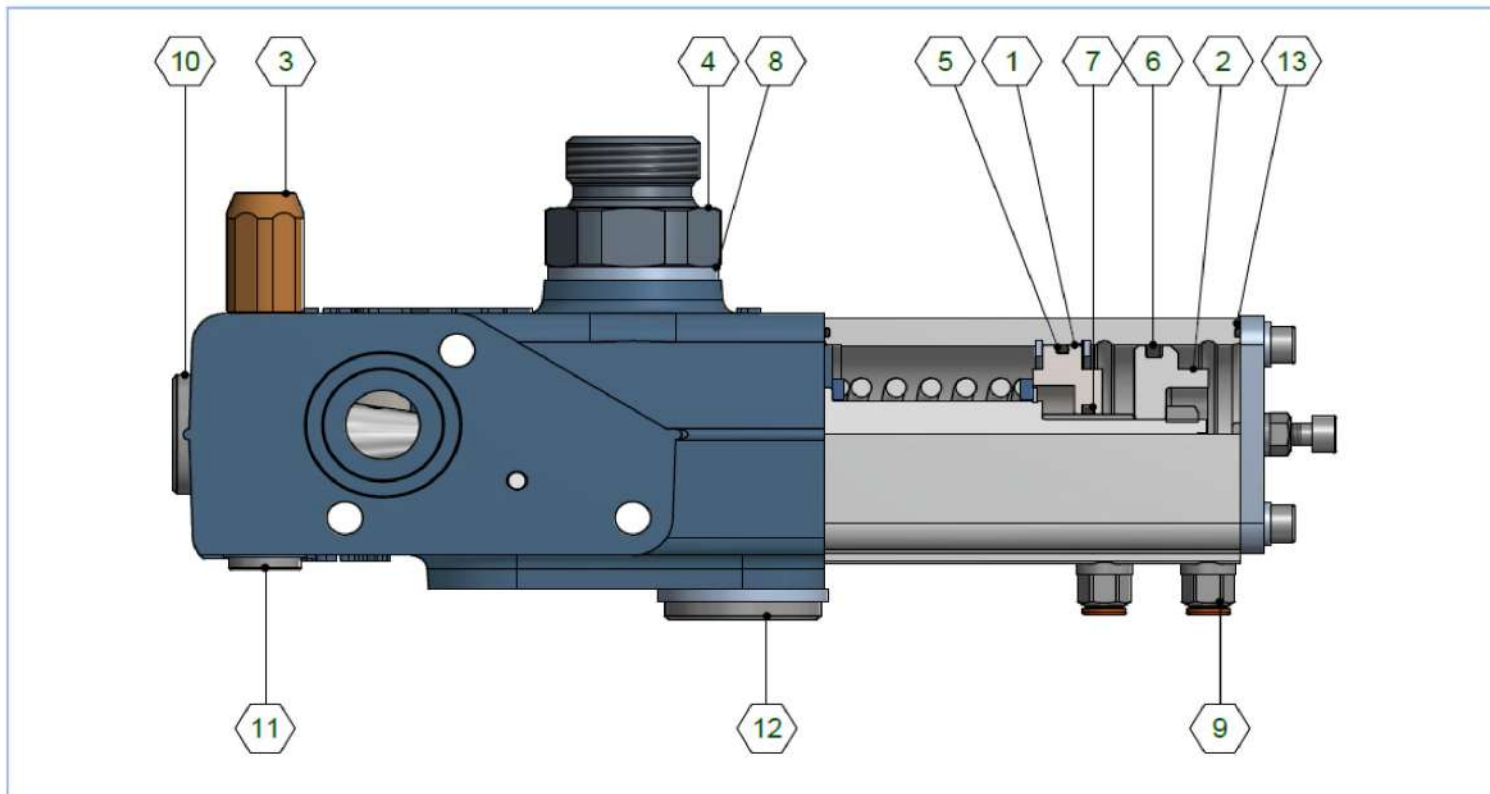

Spare Parts

No.	Part no.	Description	Qty
1	14845005	closing plate	1
2	14845007	piston air cylinder	1
3	14772...	cartridge pressure relief	1
	14772110	110 bar	1
	14772135	135 bar	
	14772150	150 bar	
	14772170	170 bar	
	14772190	190 bar	
	14772220	220 bar	
	14772250	250 bar	
	14772280	280 bar	
	14772350	350 bar	

No.	Part no.	Description	Qty
4	14739975A	non return valve	1
5	14845013	O-ring	1
6	14845020	Quadring	1
7	14845018	Quadring	1
8	01313848	bonded seal	2
9	14810517	straight coupling	2
10	14845024	blind plug	1
11	14845039	blind plug	1
12	14845040	blind plug	1
13	01226200	O-ring	2

HT valve: Hydraulic symbol

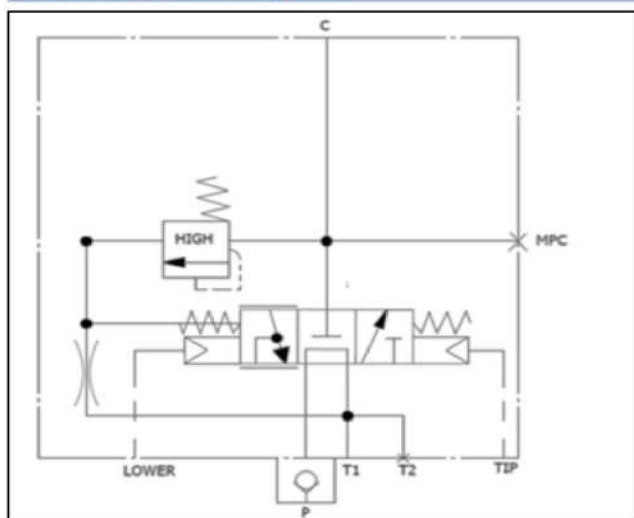

Този продукт се предлага от:



HYDRAULIC PARTS & EQUIPMENT

Гр. София, ул. Челопешко шосе 10-12
 0886 441 442 / 0898 447 449
www.hydraulicstore.eu