

GHS 175-5-7100 H TEL.SİL.

Product Code : 43175571006

Reference No : 22-001

Plastik Kapak
(Plastic Cover)

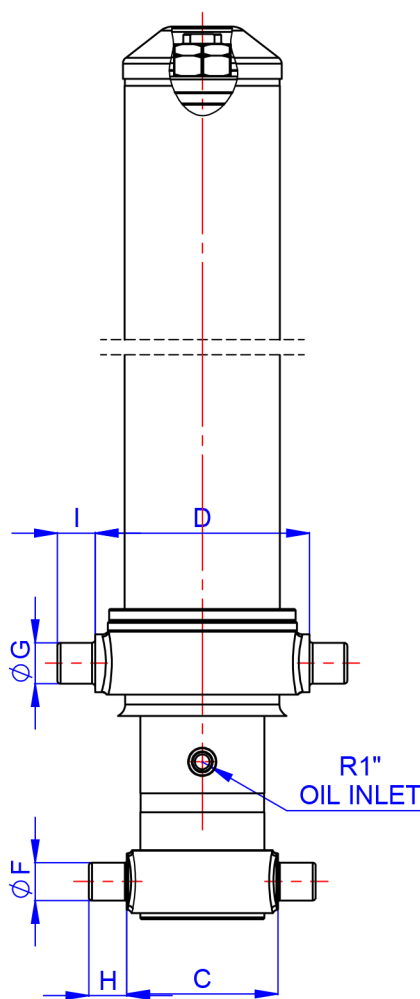
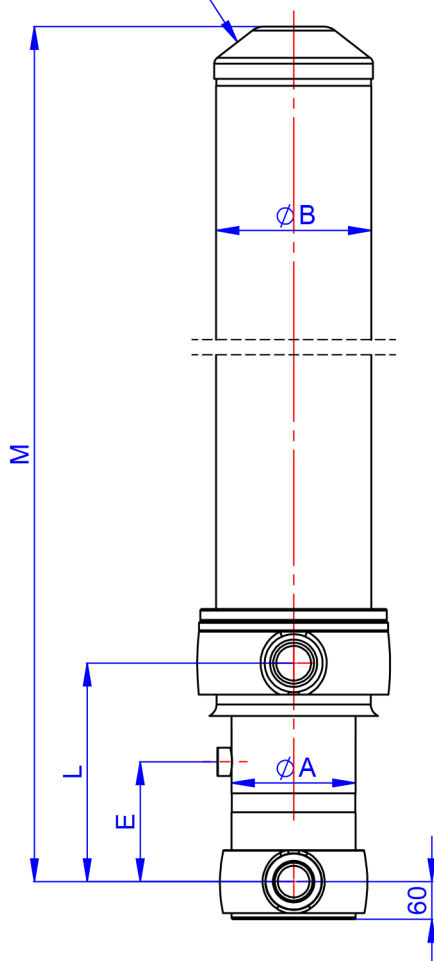

- A : 197
- B : 245
- C : 240
- D : 340
- E : 190
- F : 60
- G : 65
- H : 60
- I : 60
- J :
- K :
- L : 346
- *L : +30
- M : 1787
- N :
- O :
- P :
- R :
- S :
- S1 :
- T :
- U :
- V :
- W :
- Y :
- Z :

EFFECTIVE DIAMETER (mm)				175	155	135	116	98		
STROKE (mm)				1420	1420	1420	1420	1420		
THRUST AT 170 BAR (TONS)				40.5	31.7	24.1	17.8	12.7		

All sizes were given as mm

SPECIFICATIONS

- Stroke : 7100
- *Inc 30 mm pull out : Tolerance +20 ; 0
- Working pressure : 170 Bar
- Max. working pressure : 190 Bar
- Working Temperature : -23 °C / +80 °C
- Total Volume : 116.8 L
- Weight Cylinder : 386.35 kg
- Hard chromed all stages
- All cylinder materials are st 52 cold down tubes
- Standard cylinder is painted with RAL 1036

FORMULATION

- St : (Stroke)
- BL : (Body Length)
- Ro : (Rear Overhang)
- PI : (Pivot Length)
- C : (Bracket Length)

$$\alpha^\circ = \frac{St \times 60}{PI}$$

