

HYVA CYLINDER

714 07 595



type: UMB 191-7-2080-K263-60-3/4"-HC

tipping weight: 14-25 ton

page # 1 / 2

Stage diameters	front view cylinder		A	245
191			ØC	215
169			G ¹	528
149			I	265
129			K ¹	263
110			M ¹	99
91			ØP	100
72			ØQ	65
			S	286
			ØW	60
			X	45

¹including 20 mm pull-out [tol. -5; +30 mm]

²cylinder is delivered including oil inlet swivel adapter and cup

specifications

total stroke ¹	2080 mm
dry weight cylinder only	109 kg
total volume	32.6 L
working volume	30.2 L
maximum pressure	220 bar
maximum pump flow	61 l/min
maximum allowable thrust first stage ³	20.0 ton
oil inlet	3/4" BSP

technical notes

This cylinder is a lifting device only and may not be used as a structural member or be subjected to side load. Sideload and/or poor alignment might result in cylinder leakage. Hyva therefore strongly recommends the use of a cradle, even in instances where the cylinder only tips to the rear or to the side. The cylinder is painted black RAL9005.

For suitable hydraulic oils, please refer to data sheet OIL-0011. For details of available brackets and cradles, please refer data sheet 015BRA06.

Detailed calculations can be made using the HYVA Tipper Program, freely available from tipper.hyva.com.

³The cylinder thrust on the first stage (from the HYVA Tipper Program) must not exceed the maximum allowable (see specifications above).

tipping view

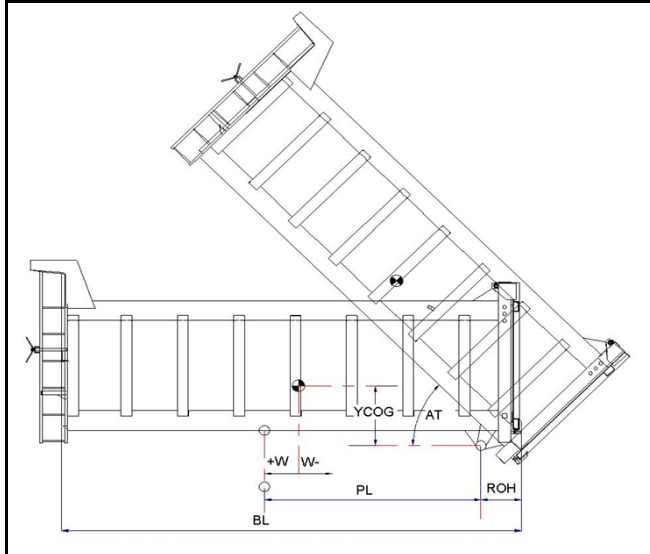

tipping weight

PL	2710	mm	2400				
YCOG	700	mm	700				
ROH	700	mm	700				
BL	6820	6200	5680	mm	6200	5640	5170
CYL w.r.t. COG (W)	0	310	570	mm	0	280	520
	Tipping weight for full stroke of 46°				Tipping weight for full stroke of 52°		
Tipping weight	14	16	19	ton	16	19	22
	Tipping weight for second last stage, up to 39°				Tipping weight for 2nd last stage, up to 45°		
Tipping weight	20	23	25	ton	20	23	25

HYVA CYLINDER

714 07 595

type

UMB 191-7-2080-K263-60-3/4"-HC

page # 2 / 2

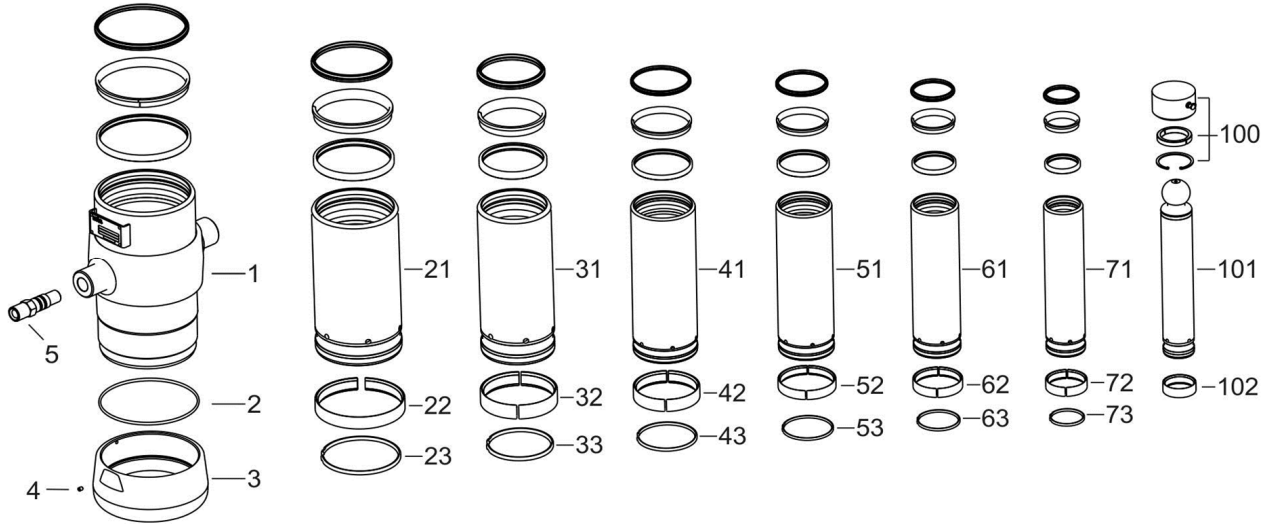

Spare part list

Pos	Part no.	Description	Qty.
1	73508300	BASE 214-0398-N0164	1
2	01226840	O-RING 208 X 4 70 SHORE	1
3	73101060	THREADED BOTTOM UM 214	1
4	01792571	LOCKING SCREW M6X12 INT. HEX. DIN 916	1
5	73103002	OIL INLET ADAPTOR UM 3/4"OT+O-RING	1
21	73607301	STAGE 191-0398-HC	1
22	71807191 K	SLIDER FL 191	1
23	71813191 K	LIFTRING FL 191x5	1
31	73606301	STAGE 169-0398-HC	1
32	71807169 K	SLIDER FL 169	1
33	71813169 K	LIFTRING FL 169x5	1
41	73605301	STAGE 149-0398-HC	1
42	71807149 K	SLIDER FL 149	1
43	71812149 K	LIFTRING FL 149/HP 150	1
51	73604301	STAGE 129-0398-HC	1
52	71807129 K	SLIDER FL 129/GF 129 (2 X 1/2)	1
53	71812129 K	LIFTRING FL 129/HP 129	1

Spare part list

Pos	Part no.	Description	Qty.
61	73603301	STAGE 110-0398-HC	1
62	71807110 K	SLIDER FL 110/GF 110 (2 X 1/2)	1
63	71812110 K	LIFTRING FL 110	1
71	73602301	STAGE 091-0398-HC	1
72	71807091 K	SLIDER FL 091 (2 X 1/2)	1
73	71812091 K	LIFTRING FL 091	1
100	01745102	RETAINER KIT UMB D.65	1
101	73401305	PISTON F 072-0398-HC	1
102	71807072 K	SLIDER FL 072 (2 X 1/2)	1

Seal kit complete

Part no.	Description
719 04 770K	Complete packset: Consists of all packsets with packset grease and o-ring.