

HYVA CYLINDER

714 18 297

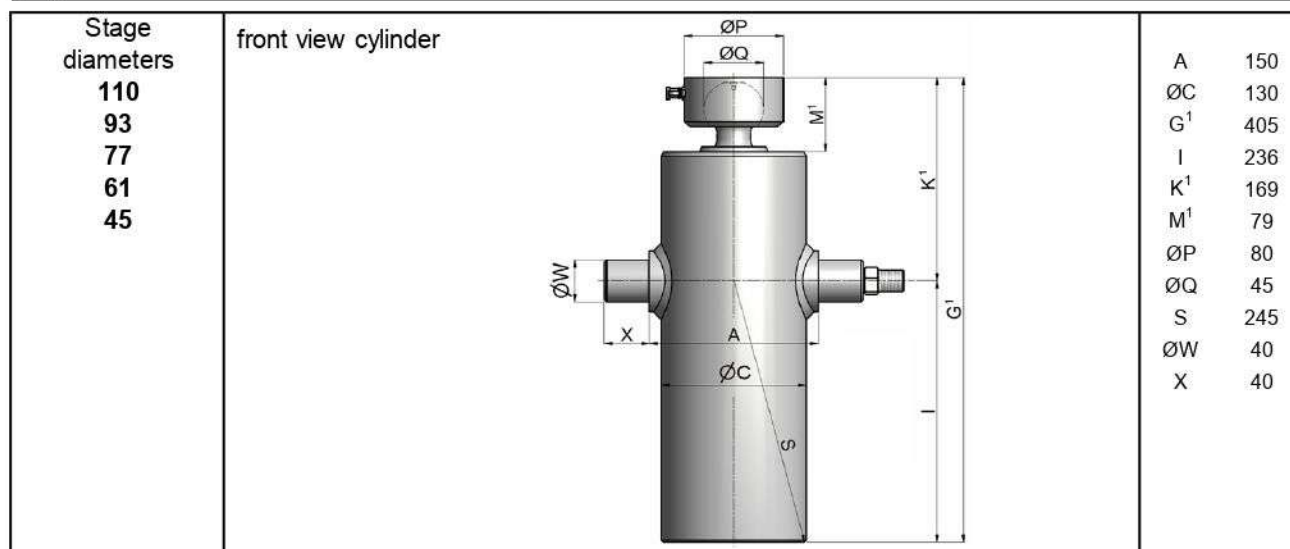

type: **ULB 110-5-1040-K169-40-1/2"-HC**
 tipping weight: **4-9 ton**
 page # 1 / 2



¹including 20 mm pull-out [tol. -5; +30 mm]

²cylinder is delivered including oil inlet swivel adapter and cup

specifications

total stroke ¹	1040 mm
dry weight cylinder only	28 kg
total volume	6.0 L
working volume	5.3 L
maximum pressure	190 bar
maximum pump flow	24 l/min
maximum allowable thrust first stage ³	8.0 ton
oil inlet	1/2" BSP

technical notes

This cylinder is a lifting device only and may not be used as a structural member or be subjected to side load. Side load and/or poor alignment might result in cylinder leakage. Hyva therefore strongly recommends the use of a cradle, even in instances where the cylinder only tips to the rear or to the side.

The cylinder is painted black RAL9005. For suitable hydraulic oils, please refer to data sheet OIL-0011. For details of available brackets and cradles, please refer to data sheet 015BRA07.

Detailed calculations can be made using the HYVA Tipper Program, freely available from tipper.hyva.com.

³The cylinder thrust on the first stage (from the HYVA Tipper Program) must not exceed the maximum allowable (see specifications above).

tipping view

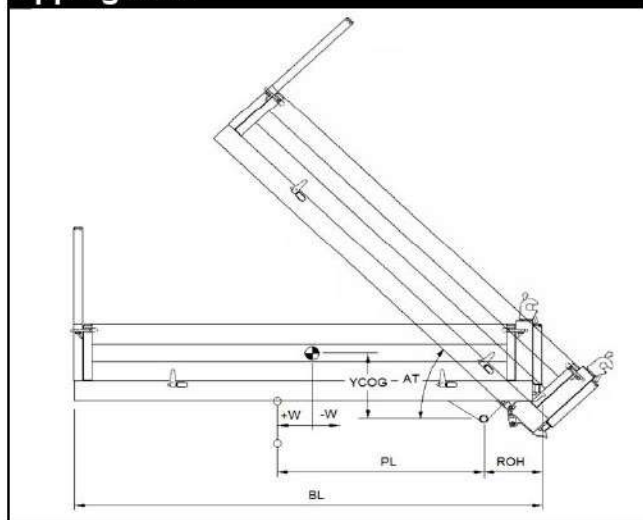

tipping weight

AT	46			deg	52		
PL	1360			mm	1200		
YCOG	450			mm	450		
ROH	450			mm	450		
BL	4020	3620	3290	mm	3670	3300	3000
CYL w.r.t. COG (W)	-200	0	160	mm	-180	0	150
Tipping weight for full stroke of 46°				Tipping weight for full stroke of 52°			
Tipping weight	4	5	6	ton	4	5	7
Tipping weight for second last stage, up to 37°				Tipping weight for 2nd last stage, up to 42°			
Tipping weight	6	8	9	ton	7	8	9

Този продукт се предлага от:



Гр. София, ул. Челопешко шосе 10-12
 0886 441 442 / 0898 447 449
www.hydraulicstore.eu

HYDRAULIC PARTS & EQUIPMENT

HYVA CYLINDER

714 18 297



type **ULB 110-5-1040-K169-40-1/2"-HC**

page # 2 / 2

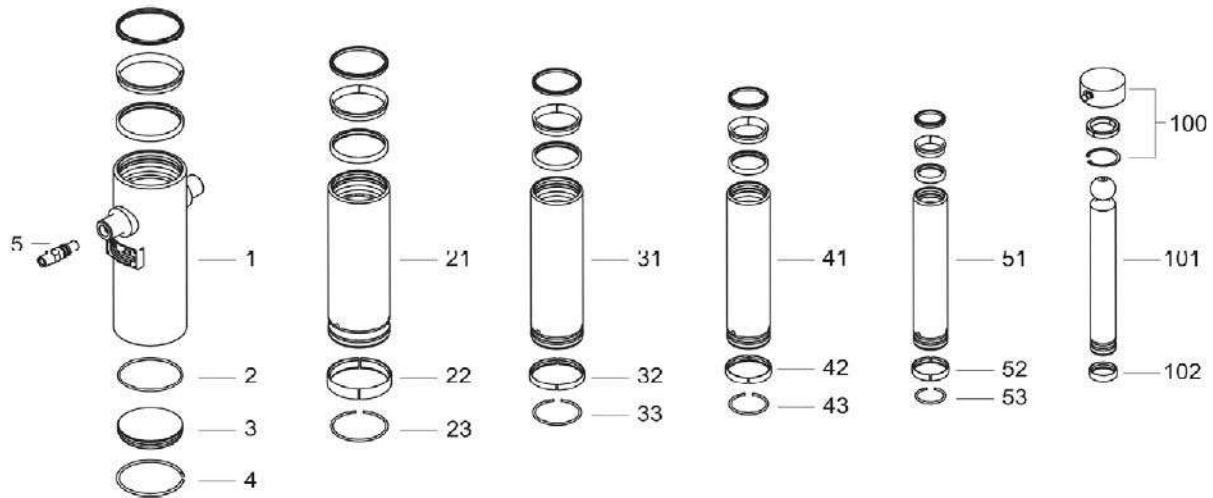

Spare part list

Pos	Part no.	Description	Qty.
1	73518300	BASE 129-0326-N0090	1
2	01226674	O-RING 107 X 4 70 SHORE	1
3	73101280 K	BOTTOM PLATE UL 129	1
4	73110129	SNAPRING BASE UL 129	1
5	73103000	OIL INLET ADAPTOR UM 1/2"OT+O-RING	1
21	73618301	STAGE 110-0298-HC	1
22	71807110 K	SLIDER FL 110/GF 110 (2 X 1/2)	1
23	73110110 K	INNER STOPRING/LIFTRING UL 110	1
31	73617301	STAGE 093-0298-HC	1
32	73111093 K	SLIDER UL 093 (2x1/2)	1
33	73110093 K	INNER STOPRING/LIFTRING UL 093	1
41	73616301	STAGE 077-0298-HC	1
42	73111077 K	SLIDER UL 077 (2x1/2)	1
43	73110077 K	INNER STOPRING/LIFTRING UL 077	1
51	73615301	STAGE 061-0298-HC	1
52	73111061 K	SLIDER UL 061 (2x1/2)	1
53	73110061 K	INNER STOPRING/LIFTRING UL 061	1

Spare part list

Pos	Part no.	Description	Qty.
100	01745100	RETAINER KIT ULB D.45	1
101	73414301	PISTON B 045-0331-HC	1
102	73111045 K	SLIDER UL 045 (2x1/2)	1

Seal kit complete

Part no.	Description
719 06 850K	Complete packset: Consists of all packsets with packset grease and o-ring.

Този продукт се предлага от:



Гр. София, ул. Челопешко шосе 10-12
0886 441 442 / 0898 447 449
www.hydraulicstore.eu

HYDRAULIC PARTS & EQUIPMENT